

# DC-DC Converter DCDC900-24-30-K1

DC Converter for Ultra-Capacitor charging in Rail Applications

## Specification

### General

Electrical Safety EN 60950, VDE 0805  
Overload- and Short circuit protected

Isolation 0.5 kV DC against case, no galvanic insulation between Primary and Secondary side.  
(Minus is pass through, but isolated against the case by EMC Y-Capacitors coupled)

### Electrical Data:

#### Input

Input Voltage Nom. Un = 24 VDC  
Input Range 16-32 VDC

#### Output

Output Voltage Nom. 29,5 VDC  
Voltage Stability  $\pm 1\%$   
Efficiency > 85 %  
Output Power Max. 900 W  
Output Current 30 A  
Type of Load UC 440F / 29,5VDC  
Current limitation Constant current, no shutdown, but temperature limited

**Ultracap Protection:** Two stage, Redundant and Diversitär

### Ambient Conditions:

Operating Temperature -40 to +70°C, acc. EN50155  
Rel. Humidity < 75%, average per year  
Schock and Vibration acc. EN50155, „mounted into frame“  
Frequency Range: 5-150 Hz  
Transfer Frequency: 8,2 Hz  
Oscillation Amplitude Below Transit Frequency: 7,5 mm  
Acceleration Amplitude Above Transit Frequency: 20 m/s<sup>2</sup>

### EMC:

Burst acc. EN50121-3-2,  
2 kV, Crit. A, direct coupled  
Surge 1,8 kV / Source 100 Ohm,  
1,0 kV / Source 2 Ohm,  
(Test not valid for Signal Contact)  
Conducted HF 3 V RMS 1kHz AM, 80%,  
150 kHz - 80 MHz  
ESD 8 kV Air, 6 kV conducted  
Emission Immunity 10 V/m 80 MHz-1GHz, 80 % AM,  
900 MHz pulse modulation



Emission, conducted 99 dB $\mu$ V QP 150 kHz- 500 kHz,  
93 dB $\mu$ V 500 kHz-30 MHz

Emission, radiated 30-230 MHz 47 dB $\mu$ V/m QP.  
230MHz-1GHz 40 dB $\mu$ V/m QP.  
10 m measuring distance

### Signal Contact:

Measuring Output Output Voltage,  
Current limited by Poly-Switch  
0,1 A, RXE 010  
Remote ON/OFF 24 VDC, <20 mA, Opto-coupler

### Mechanical Data:

Case Material Niro (Stainless Steel)  
Dimension (W x D x H) 270 x 255 x 115 mm  
Weight approx. 4,5 kg  
Protection IP 54  
Cooling natural free convection,  
out side heat-sink,

### Connection Terminals:

Input: -X1 Harting HANQ5, male, Ag 2,5 mm<sup>2</sup>  
Signal: -X2 Harting HAN8U, female, Au 0,75 mm<sup>2</sup>  
Output: -X3 Harting HANQ5, female, Ag 2,5 mm<sup>2</sup>

**Warranty** 24 Month

### Order Code

DCDC900-24-30-K1

# DC-DC Converter DCDC900-24-30-K1

DC Converter for Ultra-Capacitor charging in Rail Applications

## Specification

### Connector description and Pin out:

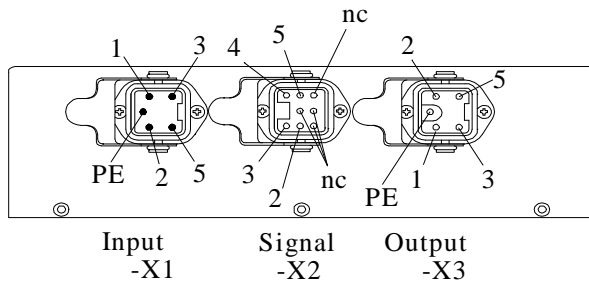

PE is connected with the case, not with the negative pole.

#### Input: -X1

1	Supply Minus
2	Supply Minus
3	Supply Plus
5	Supply Plus

#### Signal: -X2

2	Voltage reading from Converter Output: Minus (I<100 mA)
3	Voltage reading from Converter Output: Plus (I<100 mA)
4	Remote ON/OFF Plus (24 VDC / < 20 mA)
5	Remote ON/OFF Minus (24 VDC / < 20 mA)

#### Output: -X3

1	Minus
2	Minus
3	Plus
5	Plus

### Mechanical Data

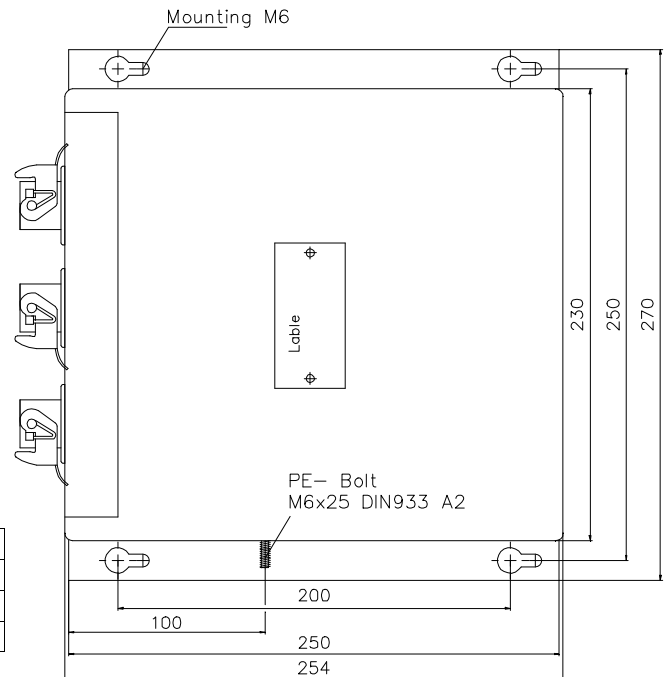

### General Information:

#### Convection requirements

Preferred mounting position of the DC-DC Converter is:  
The heat sink fins are in a vertical direction.

#### Connector mounting height

The mounting height of the electrical connectors (incl. opposite connector) is 90 mm + bending radius of the cables.

#### Protective Earth (PE) -Bolt

The DC-DC Converter has a PE-Bolt, size M6 x 25, located on the side of the housing. The minimum required cable square size for this connection is 4 mm<sup>2</sup>. The PE-Bolt is not connected with the Converter Minus pole.

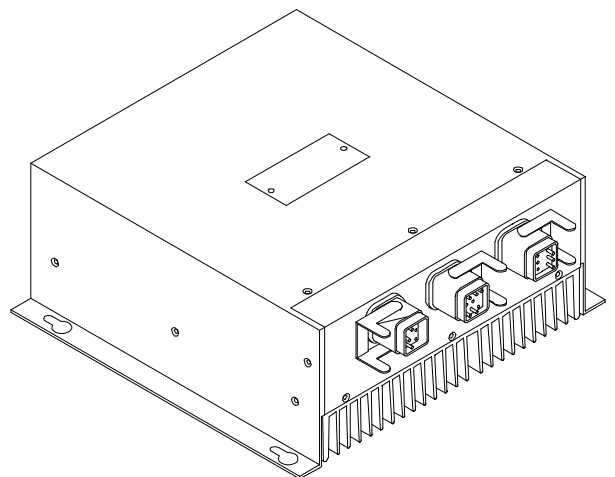

# DC-DC Converter DCDC900-24-30-KI

DC Converter for Ultra-Capacitor charging in Rail Applications

## Specification

### Converter Topology

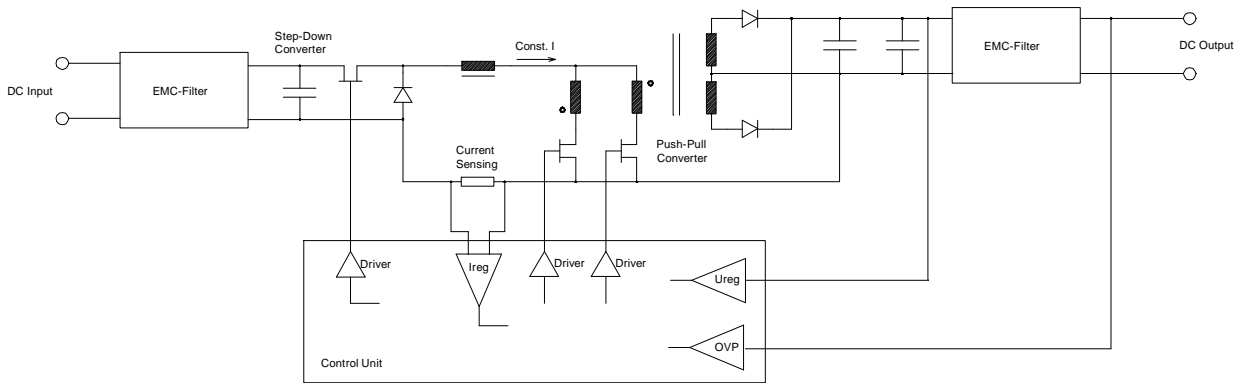

### Charging Curve with a UC 440 F load:

